

Control System Development and Systems Engineering Solutions



<http://www.emmeskay.com/>
info@emmeskay.com

EMMESKAY, INC.

47119, Five Mile Road
Plymouth, MI 48170 USA
Phone: (734) 207 – 5564
FAX: (734) 207 – 5556

EMMESKAY SYSTEMS SOLUTIONS Pvt. Ltd.

20 Kannadasan Salai, T. Nagar,
Chennai 600 035 INDIA
Phone: +91 – 44 – 4207 0231
FAX: +91 – 44 – 4207 0243

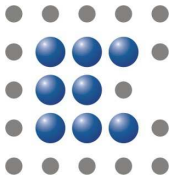

Emmeskay - Company Facts



- US based company with head office in Detroit, USA and a fully owned subsidiary in Chennai, India
- Emmeskay, Inc. started operations in 1998 in Detroit
- Emmeskay – India started operations in 2002 in Chennai
- Commercially represented by NEAT Corporation in Japan
- Global customer base is served by the global resource base

- Vision
 - Emmeskay will be recognized as a world-class, global business that provides advanced technology solutions in harmony with the environment and the society
- Mission
 - To promote Math Model Based Controls Development and Systems Engineering
 - To grow Company Value

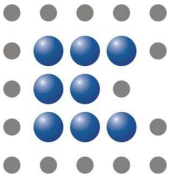

Resources

- More than 60 people spread between our US, India and Japan (NEAT) offices
 - Several people with advanced degrees in engineering (MS and PhD)
 - Multi-disciplinary backgrounds – ME, EE, ChE, CS
 - People with prior experience within the auto industry

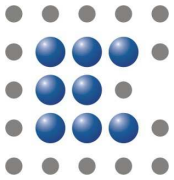

Core Competencies

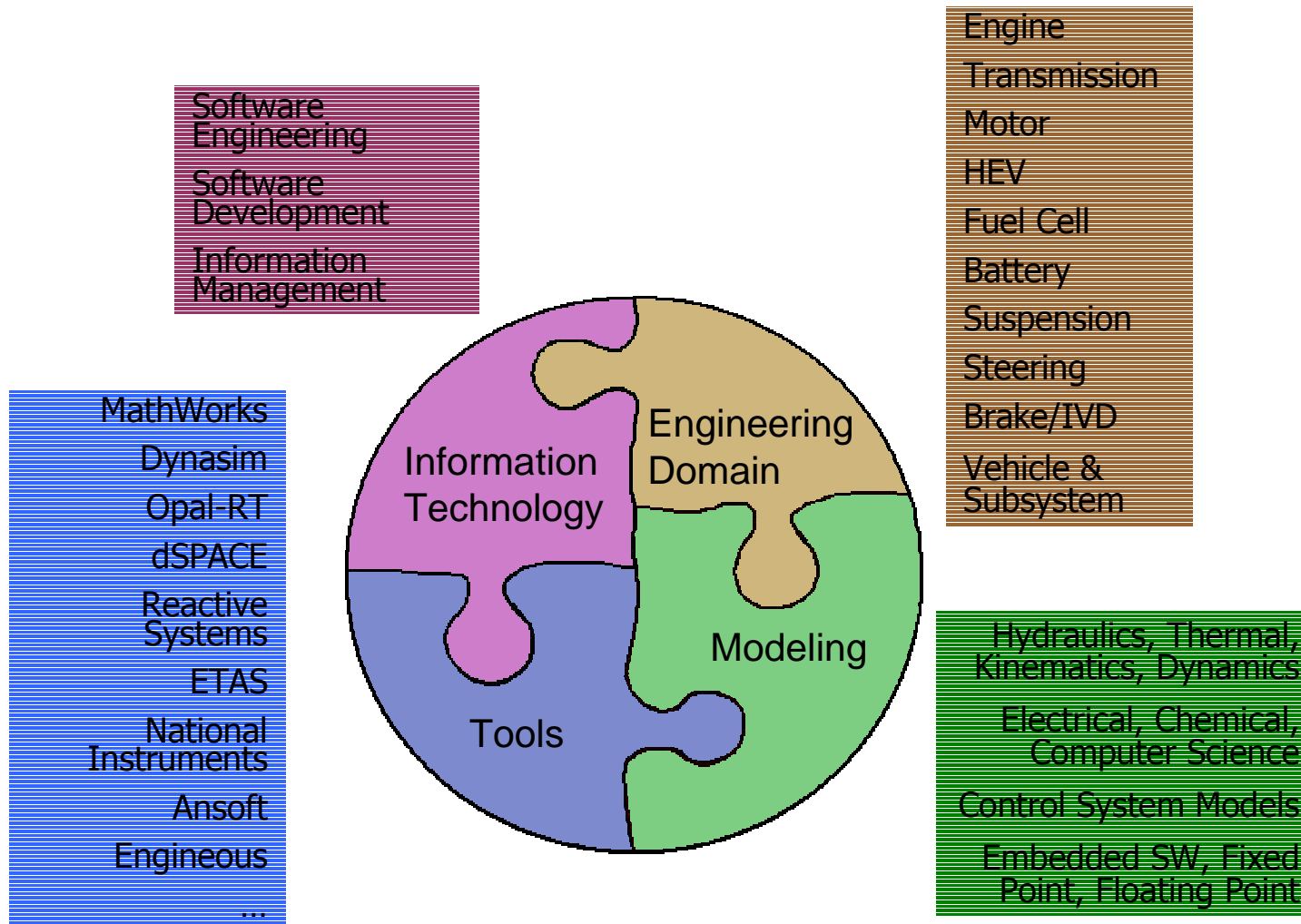

Engineering, Science, and IT – Integrated Solutions

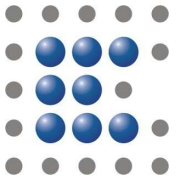

Areas of Expertise

The blend of core competencies has been applied in a wide variety of consulting projects.

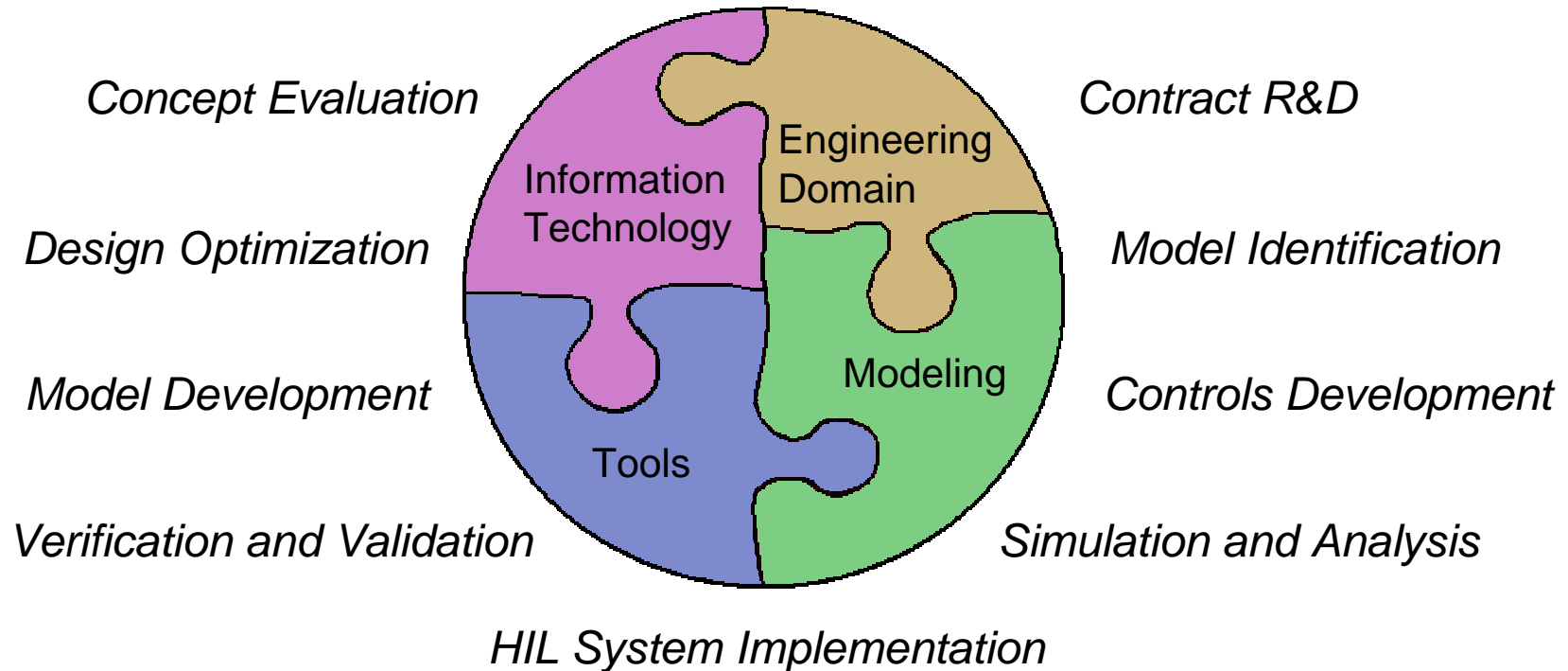

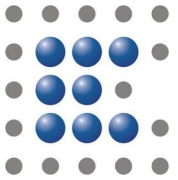

Overall Value Proposition

- Expertise in MBSD: Emmeskay provides technical solutions that judiciously combine:
 - Engineering domain expertise
 - Modeling expertise
 - Tools expertise
 - Information technology expertise
- Good understanding of methods and processes in the mobility industry
- Tool neutral position
- Nimble and flexible business practices
- Experience over a wide range of technically challenging projects

All of the above reasons give Emmeskay a unique ability to serve our customers' complex needs

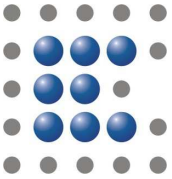

Customer Feedback

- Mary Ann Wright, Hybrid Escape Chief Engineer, Ford Motor Company
 - *I have been very impressed with the responsiveness and proactiveness of your team. Thank you!*
- CEO, Global Tier 1 Automotive Supplier
 - ... *Our internal feedback indicates that the team is very happy with your team's knowledge, capability and quality of delivery. ...*
- Group Leader, Advanced Products Division, Global Tier 1 Automotive Supplier
 -*I have thoroughly enjoyed the relationship I have had with Emmeskay. I find your organization's people to be experts, while at the same time with a degree of humility which makes working with your people a pleasure.*
- General Manager, R&D Division, Leading Two-Wheeler Manufacturer
 - *Phase I of the project went extremely well. The Emmeskay team, both from US and Chennai, has done an excellent job. I would like to commend the team on the wonderful work that they have done. Our engineers are impressed with the quality of work. Further, they, and their seniors think that the simulation tool will be very useful for doing upfront vehicle performance prediction and design...*
- Lead Project Engineer, Advanced Products Division, Global Tier 1 Automotive Supplier
 -*In my opinion, the success of the controls development is a direct result of Emmeskay's brilliance and hard work. I have worked with many suppliers in my 30 year career and you guys are simply the best.*

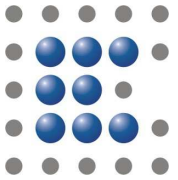

Control System Development Process

Development process can be represented by a Systems Engineering V-diagram

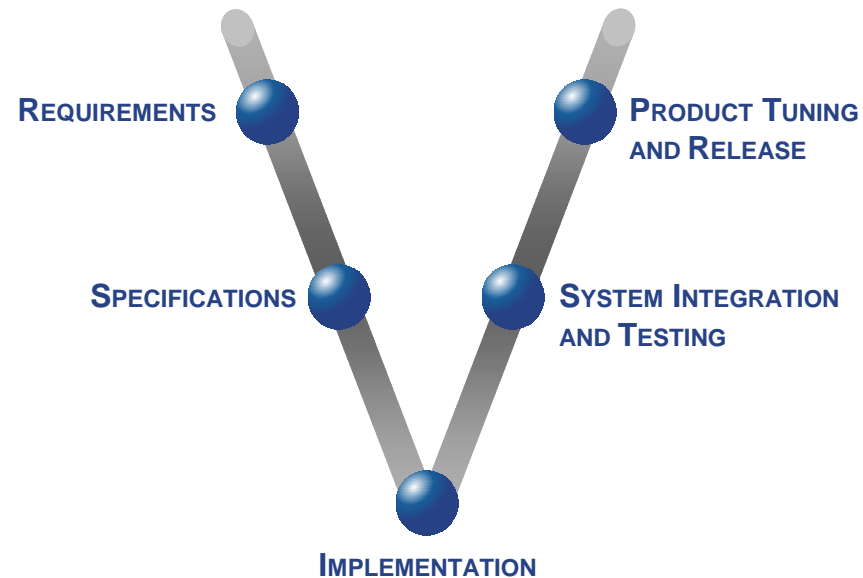

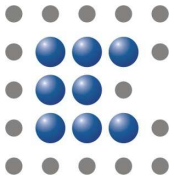

What is MBSD?

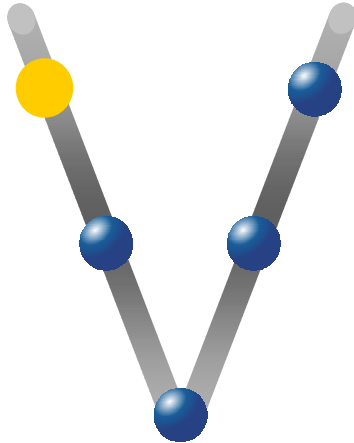

- **Plant Model Development and Analysis**

- Vehicle system model is used to analyze the vehicle performance and derive subsystem/ component requirements from vehicle/subsystem requirements

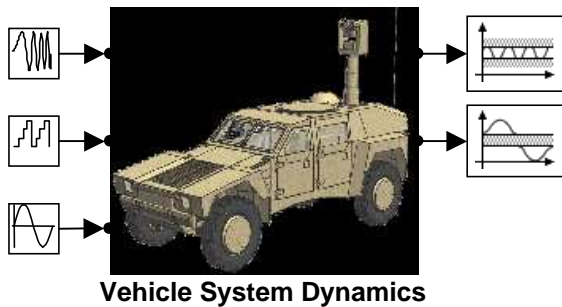

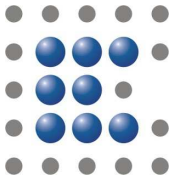

What is MBSD?

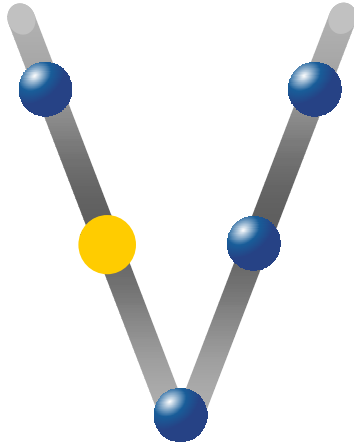

- **Plant Model Development and Analysis**

- Vehicle system model is used to analyze the vehicle performance and derive subsystem/ component requirements from vehicle/subsystem requirements

- **Controller Design**

- Models of the controller are constructed and are tested against vehicle system models through simulation in an iterative process to check if requirements are satisfied

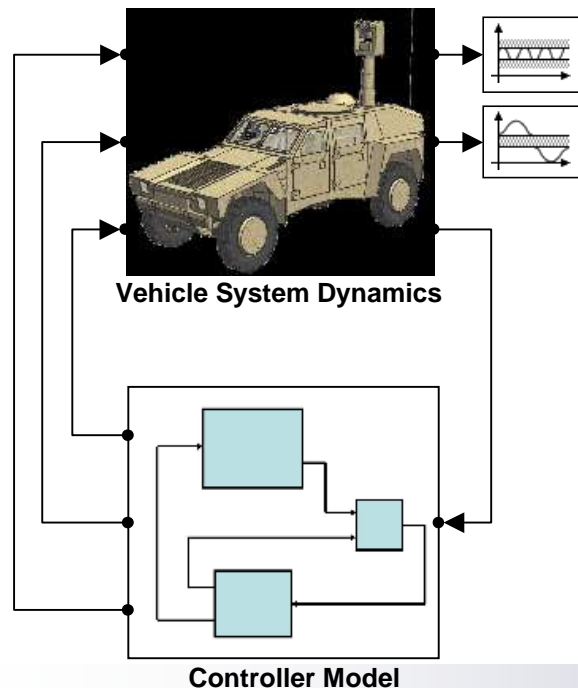

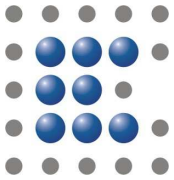

What is MBSD?

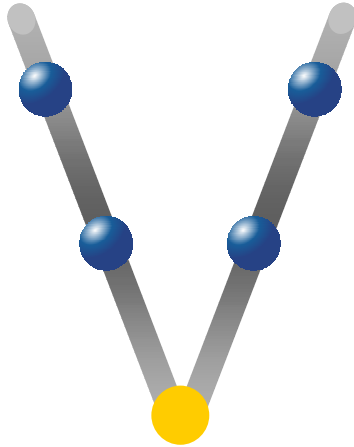

- **Plant Model Development and Analysis**

- Vehicle system model is used to analyze the vehicle performance and derive subsystem/ component requirements from vehicle/subsystem requirements

- **Controller Design**

- Models of the controller are constructed and are tested against vehicle system models through simulation in an iterative process to check if requirements are satisfied

- **Implementation**

- Embedded C-code is automatically generated from the controller models

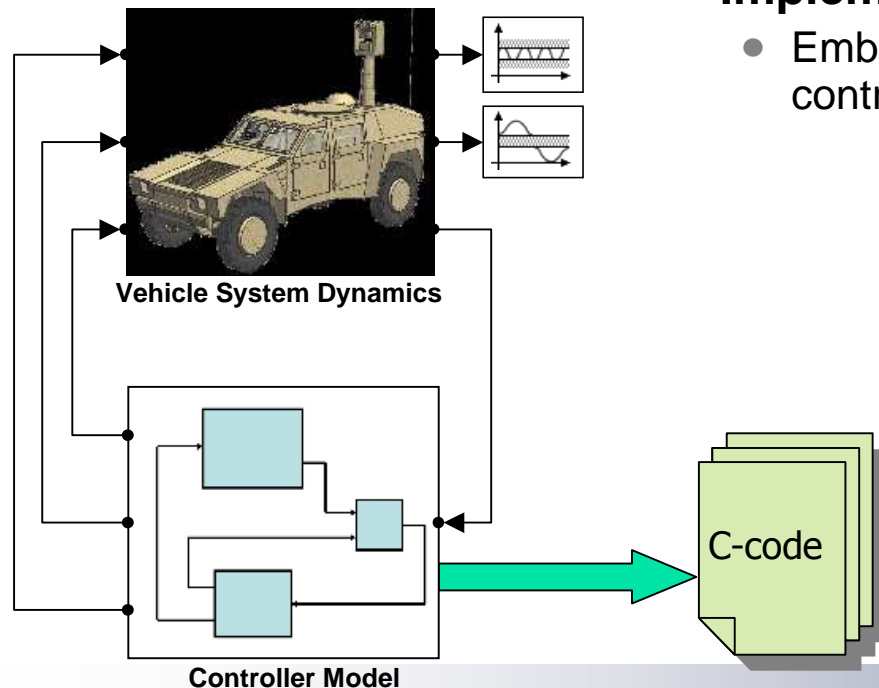

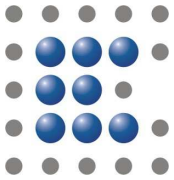

What is MBSD?

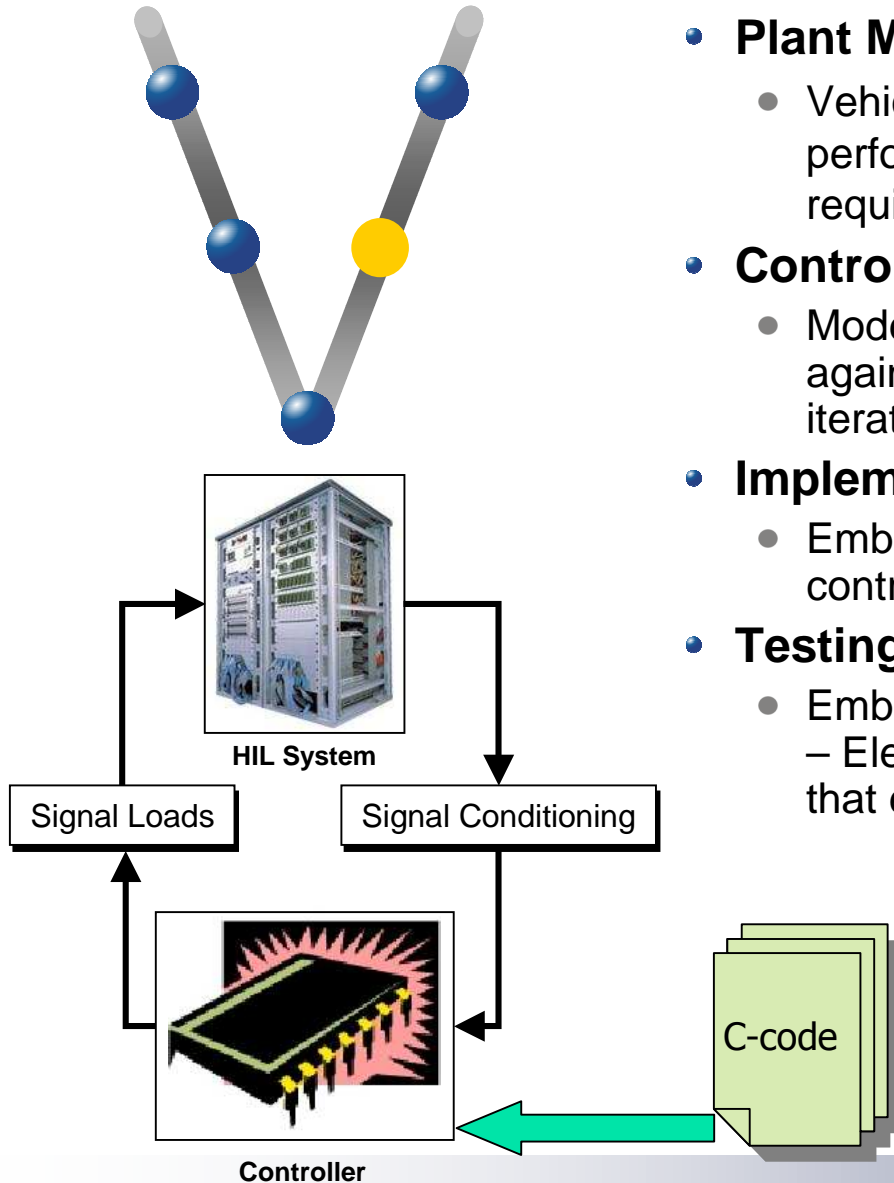

- **Plant Model Development and Analysis**

- Vehicle system model is used to analyze the vehicle performance and derive subsystem/ component requirements from vehicle/subsystem requirements

- **Controller Design**

- Models of the controller are constructed and are tested against vehicle system models through simulation in an iterative process to check if requirements are satisfied

- **Implementation**

- Embedded C-code is automatically generated from the controller models

- **Testing**

- Embedded C-code running on the target processor (ECU – Electronic Control Unit) is verified on a test platform that emulates actual vehicle behavior

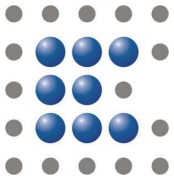

What is MBSD?

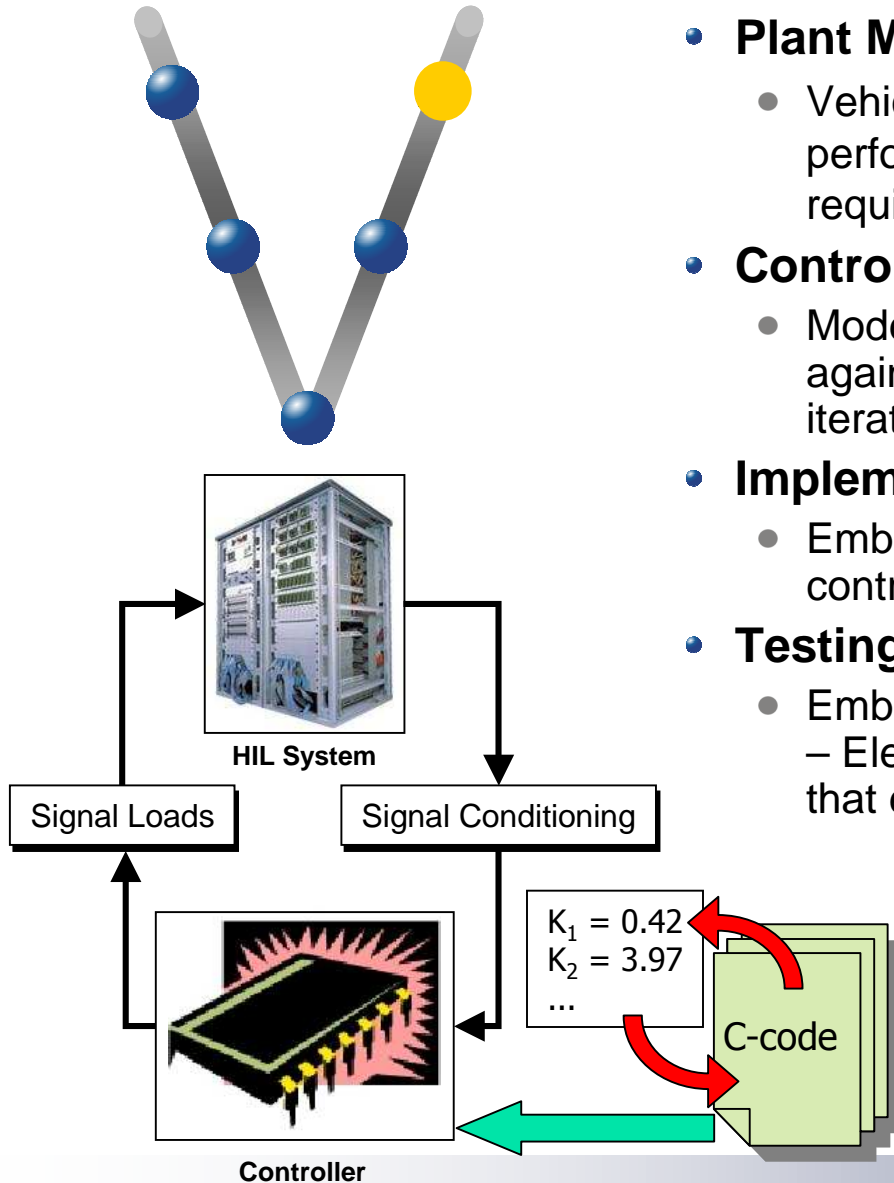

- **Plant Model Development and Analysis**

- Vehicle system model is used to analyze the vehicle performance and derive subsystem/ component requirements from vehicle/subsystem requirements

- **Controller Design**

- Models of the controller are constructed and are tested against vehicle system models through simulation in an iterative process to check if requirements are satisfied

- **Implementation**

- Embedded C-code is automatically generated from the controller models

- **Testing**

- Embedded C-code running on the target processor (ECU – Electronic Control Unit) is verified on a test platform that emulates actual vehicle behavior

- **Calibration**

- With the vehicle system model emulating the actual vehicle, the ECU is calibrated to meet requirements before calibration is done on the real vehicle

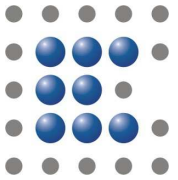

Products and Services

Spans the entire control systems development process

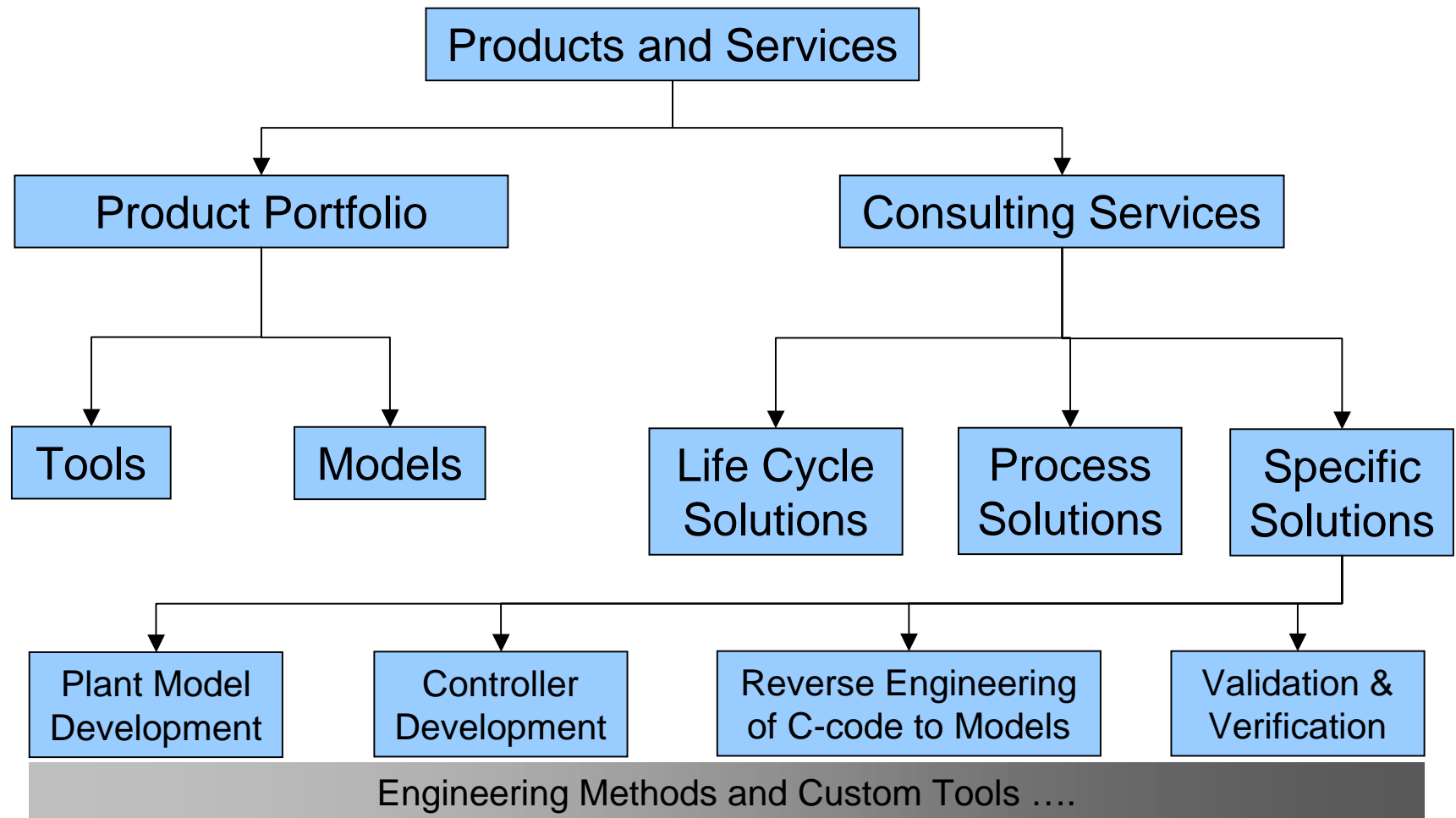



Thank you for your time

<http://www.emmeskay.com/>

info@emmeskay.com